

OWNER'S MANUAL

**Baby Otter
2000 - 3000**

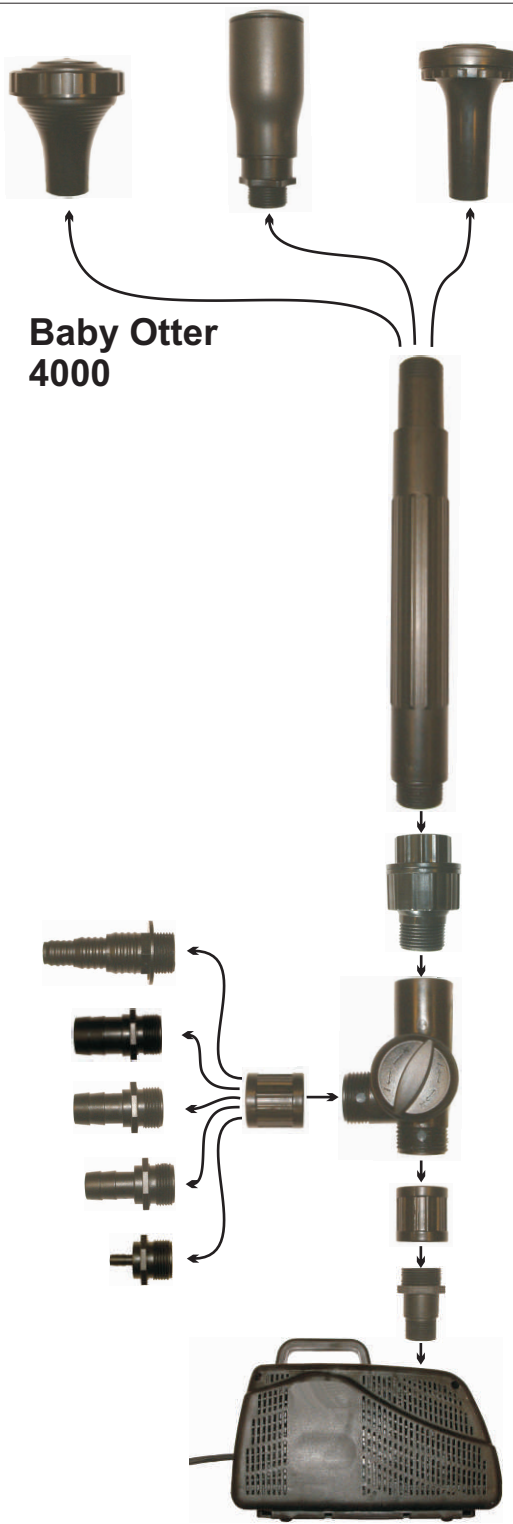

**Baby Otter
4000**



Introduction

Lotus pumps are carefully inspected and tested to ensure both safety and operating performance. Failure to follow the instructions and warnings in this manual may result in pump damage and/or serious injury. Please read and save the manual for future reference.

Electrical Connections

The pump comes complete with 10 metres of 3 core rubber cable, however, if you need to extend the cable, you should use a suitable length of 3 core rubber cable and an Oasis Waterproof (IP68) cable connector. *(Please ask your retailer)*

This unit is designed for permanent installation to the mains. The power supply should be earthed and fused at 3amps. **A residual circuit device (RCD) must be fitted to the mains supply.**

For permanent installation to the mains supply, it is necessary to comply with the regulations of the Local Electricity Authority.

Consult a qualified electrician if in doubt about any aspects of wiring.

The wires are colour coded as below.



Pump User Guide

CAUTION: Do not let the pump run dry.
Do not lift the pump by the power cord.

Performance

A clogged or dirty filter cage will greatly reduce the performance. If the performance is lost, this is an indication that the pump requires cleaning. Do not allow the pump to run if not submerged in water.

Cleaning/Maintenance

⚠ Always disconnect the pump from the mains electricity supply before attempting maintenance, cleaning or handling of any kind.

To clean the pump/cage, first remove the pump from the pond. The cage will open via two push clips at the top. (The 4000 model has 2 screws). The cage can now be cleaned in a bucket of water or using a garden hose to free any debris.

To clean the impeller of the pump, first you need to remove the impeller holder. (See diagram). To remove the impeller holder, turn it anti-clockwise. Be careful not to lose the rubber sealing ring. The impeller can now be removed from the pump body. Be careful not to break the ceramic shaft running through the centre of the impeller. The Pump body and impeller can now be cleaned in a bucket of pond/tap water. **Caution: Do not clean any components in detergents or any cleaning agent.** Once all parts are cleaned, they can be re assembled in reverse order as above.

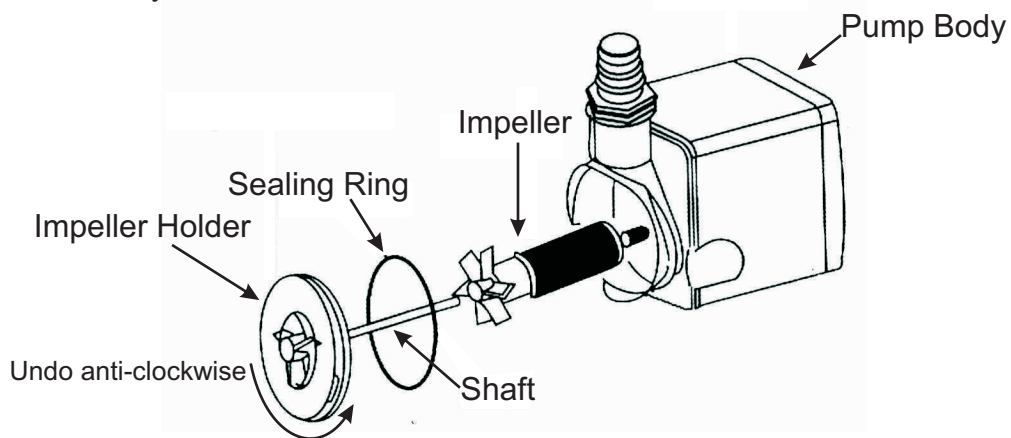

Guarantee

Your Otter Baby Pump is guaranteed against failure due to defective workmanship or materials for a period of 24 months from the date of purchase. Failure caused by accidental damage, misuse, neglect or used in liquids other than cold water are excluded from this guarantee. If a failure occurs during this period, a purchase receipt must be produced. The unit will be either repaired or replaced at the companies option. The company cannot accept any additional claims for consequential losses. All "ware and tear" items are excluded from this guarantee. This guarantee does not affect your statutory rights.

OAL Water Garden Products Ltd.
Oasis House, Deer Park Industrial Est.
Knowle Lane, Fair Oak, Hants, SO50 7PZ
+44 (0) 23 8060 2602
www.oalwatergardens.com



Fountain Assembly

Baby Otter 750



Baby Otter 1200 - 1500

